

2008 New Edition

powerline Cable Reel

Application of Moving Cart ◦ Hoist System ◦ Machine Equipment ◦ Gate Opener ◦ Watering can



Tunnel Access



Dam Gate



TRSC Crane for Carriage Moving



Gantry Crane



Factory Grab

Part1 Spring Cable Reel

Definition of Our Type

●PWLS1、PWLS11

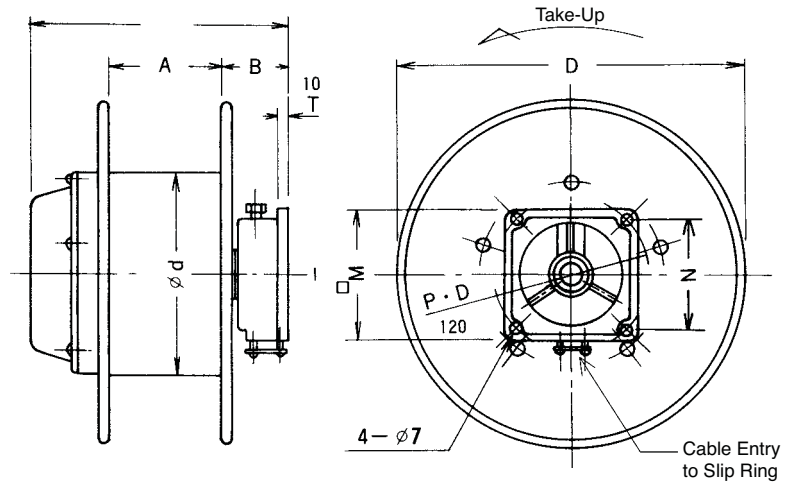
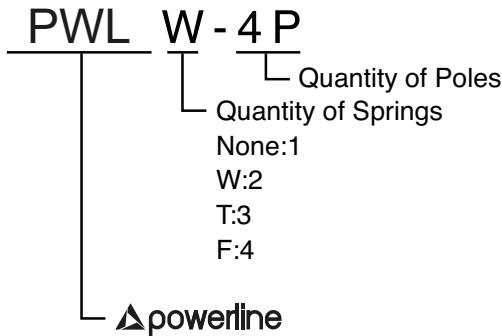

●Sheave Guide Chart

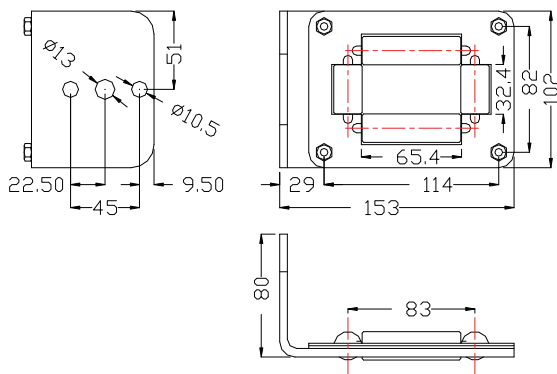

●Bracket Chart

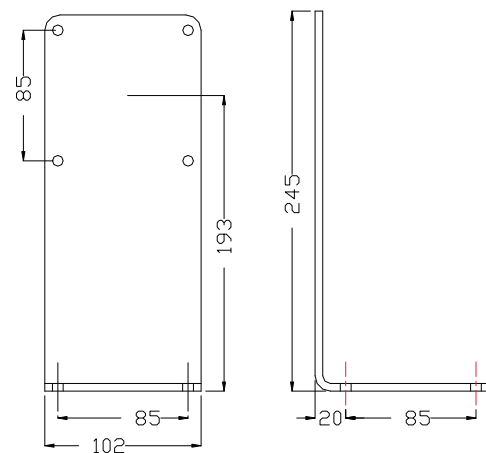

Specification and Dimension

Type	Max Length (horizontally furl)	Maximum		Reel Dimension									Weight (kg)
		Amps	Poles	A	B	C	D	d	H	L	M	N	
PWL1	2X3 10M	15A	8P	93	55	195	290	160	340	195	105	85	8
PWL11	2X3 13M	15A	8P	90	60	195	320	200	355	205	110	85	10
PWL2W	3.5X3 18M	30A	12P	110	85	225	400	230	425	310	145	125	14
PWL216W	5.5X3 16M	30A	12P	110	85	225	400	230	425	310	145	125	16
PWL3W	3.5X3 25M	30A	12P	110	85	275	500	230	525	310	145	125	18
PWL4W	5.5X3 18M	40A	16P	90	120	195	500	285	545	368	235	195	32
PWL4T	5.5X3 27M	40A	16P	168	120	380	650	285	705	438	235	195	41
PWL4F	5.5X3 38M	40A	16P	168	120	380	650	285	705	438	235	195	45
PWL4F20	14X3 22M	40A	4P	168	120	380	650	285	705	438	235	195	46
PWL5T	8X3 36M	40A	16P	160	130	380	650	353	705	450	235	245	68
PWL5T20	14X3 26M	60A	4P	160	130	380	650	353	705	450	235	245	75
PWL5F	8X3 48M	40A	16P	160	130	380	650	353	705	450	235	245	72
PWL6F	14X3 56M	60A	4P	205	160	440	750	440	815	500	300	260	110

● PWLS2W、PWLS3W

● PWLS4F、PWLS4W、PWLS5F
PWLS5T、PWLS6T

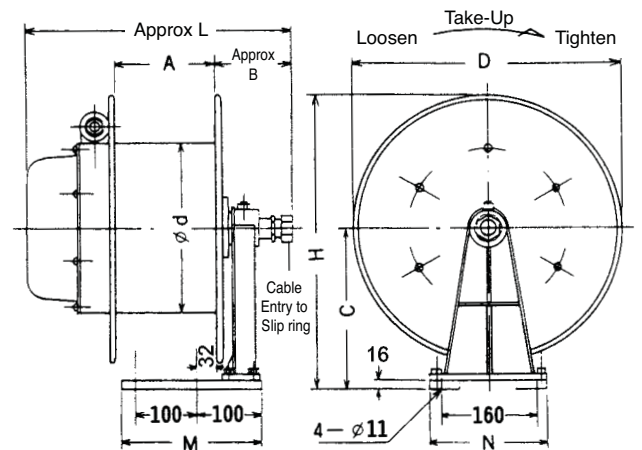
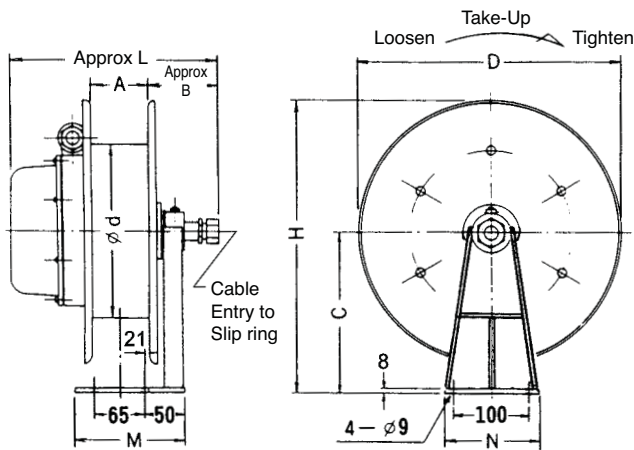

How to Choose Your Type

1. Cable's diameter should be under flange's .
2. Cable weight (per meter) × Length < Maximum Reel Torque
Ex: 3.5mm/4C as Cable Dim shows 0.41 kg/m, 10m×0.41 kg/m = 4.1kg < (7kg)
Cross-refer the Specification (P.5) find the Choice is PWL216W.

Type	Cable Entry Flange Dim. mm	Annulus	Max Winding Force F (kgf)	Max Torque kgf*m
PWL 1	14	15	2	0.2
PWL 11	13	13	3	0.3
PWL 2W	13	22	3.5	0.4
PWL 216W	16	20	7	0.8
PWL 3W	13	35	3.5	0.4
PWL 4W	22	25	7.5	1.06
PWL 4T	22	37	7.5	1.06
PWL 4F	22	50	7.5	1.06
PWL 4F20	22	26	17	2.42
PWL 5T	26	37	10	1.76
PWL 5T20	26	30	17	3.0
PWL 5F	26	50	10	1.76
PWL 6F	33	60	24	5.28

Reel mounted on the moving equipment will be an effort-saving way.

Design(Cross-refer Questionnaire)

Definition

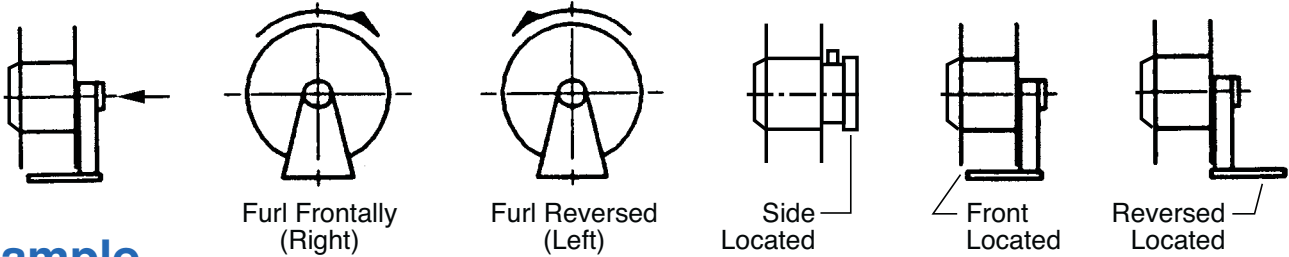

Example

Reel Mounted on Equipment	Reel Mounted on Equipment
1. Horizontally Furl $fe > (w \times \ell) \times 9.807$ $\ell \doteq 2h$	6. Horizontally Furl $Fe > W \times (\ell + L') \times \mu \times 9.807$ $\mu \doteq 0.7 \sim 0.6$
2. Horizontally Poised Furl $Fe > \frac{w \times L^2 \times 9.807}{8 \times S}$	7. Horizontally Poised Furl $Fe > \frac{w \times L^2 \times 9.807}{8 \times S}$
3. Upright Setting $fe > w \times 9.807$	8. Upright Setting $fe > w \times 9.807$
4. Downward Setting $Fe > (w \times L + \Delta) \times 9.807$ $\Delta = \text{Weight of Load (kg)}$	9. Downward Setting $Fe > (w \times L + \Delta) \times 9.807$ $\Delta =$
5. Horizontally/Middle Power In <p>Fe calculates as Type 1</p>	10. Horizontally/Middle Power In <p>Fe calculates as Type 6</p>

Fe = Max Efficient Winding Force(kgf)
 fe = Beginning Winding Force(kgf)
 L = Max Furl Length
 W = Cable Weight (kg/m)
 L' = Length on Ground
 ℓ = Free Length (m)
 S = Poised Drop Allowable Length
 μ = Efficient Value

Efficient Winding Force(kgf)

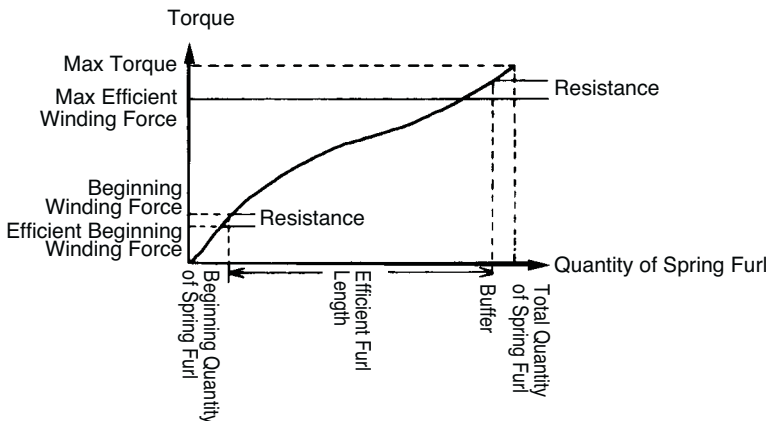

$$\text{Max Winding Force } F(\text{kgf}) = \frac{\text{Max Torque (kgf} \cdot \text{m)}}{\text{Reel Radius (m)}}$$

$$\text{Max Efficient Winding Force } Fe(\text{kgf}) = \mu \cdot F(\text{kgf}) \quad \mu = 0.7$$

When quantity of poles is over 4 or speed is over 40 m/min or other resistant cause occur, by all means add the buffer (reduce the μ Efficient Value).

Cable Dim

Type Poles Conductor Cross Section Area mm ²	3 poles		4 poles	
	O.D mm	Weight kg/m	O.D mm	O.D mm
1.25	11.5	0.195	13.0	0.245
2.0	12.5	0.23	13.5	0.285
3.5	14.0	0.33	15.5	0.41
5.5	15.5	0.43	17.5	0.54
8.0	17.0	0.54	19.0	0.69
14.0	22.0	0.905	25.0	1.15
22.0	28.0	1.73	31.0	1.82
(30.0)	33.0	1.96	36.0	2.5
38.0	35.0	2.34	39.0	3.0
(50.0)	39.0	2.85	43.0	3.64
60.0	42.0	3.45	47.0	4.41
(80.0)	49.0	4.64	55.0	5.94
100.0	54.0	5.63	60.0	7.2

Spring cable reel installment

Step

1. Power-in terminal enter "D" slip ring unit through "G" hollow axis, connected with "E" slip ring. (chart 1)

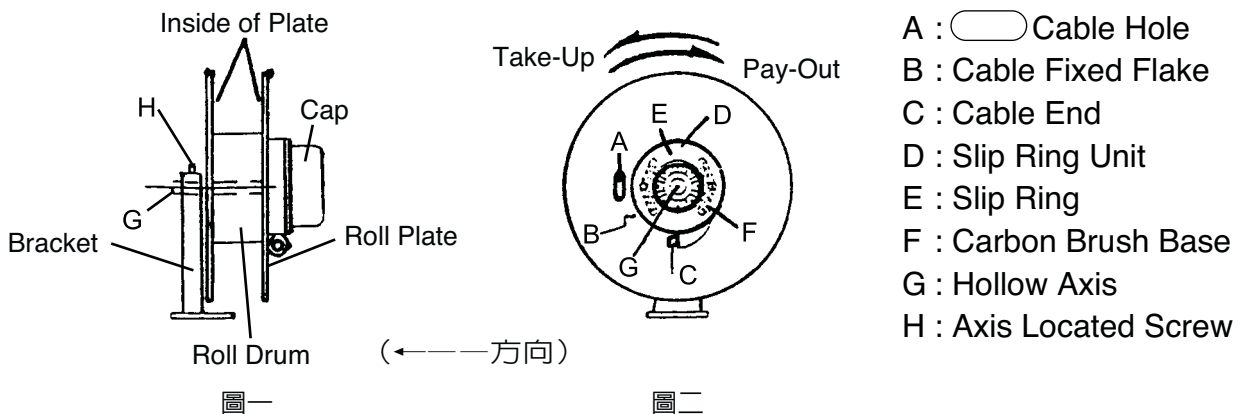

2. Cable pierces "A" hole from the inside of roll plate and through "B" fixed point into "C" cable end. Connect the cable with carbon brush and arrange the cables. Lock the outside cap after connection. *Avoid cable hooking the screw parts, cables in the spring ring unit should be leaned aside as possible as you can. (chart 2)

3. Roll all cables clockwise in the roll plate (chart 3), or handle the cable and move roll plate anti-clockwise till all cables completed (chart 4)

4. Locate the cable reel.

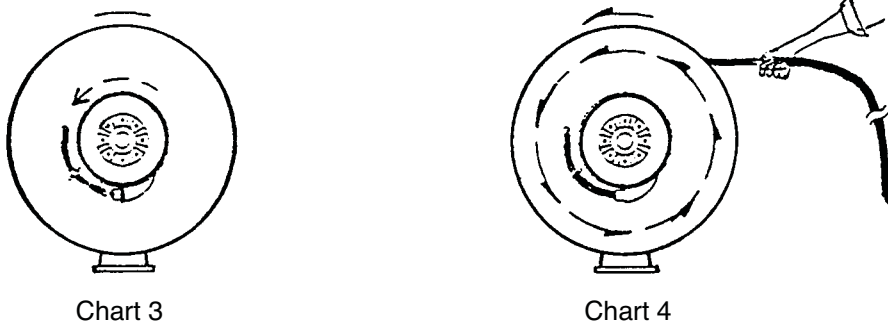

5. Move the plate 2-3 cycles (snail shape spring will save the kinetic energy). Pull cable out through the sheave guide; make a trial run after connect power.

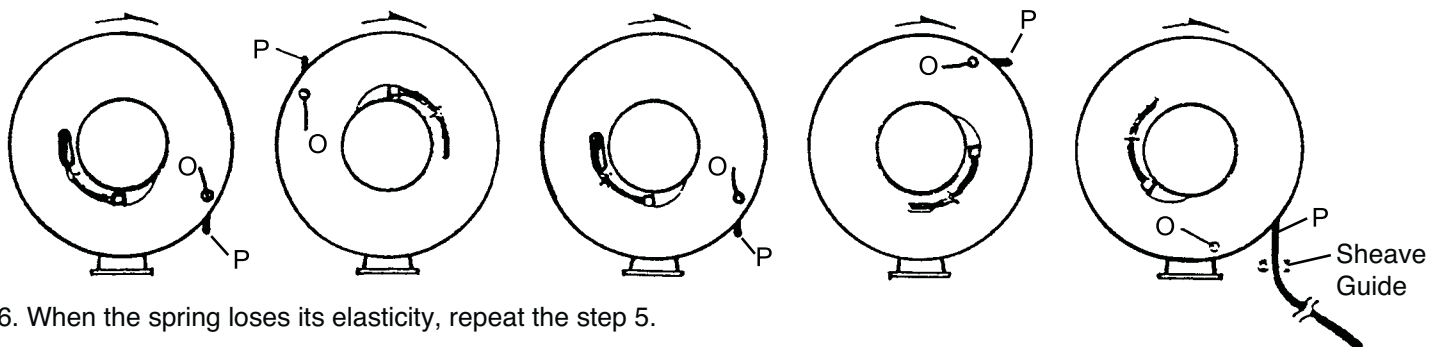

6. When the spring loses its elasticity, repeat the step 5.

7.

Moving cart roll horizontally



with sheave guide.
(recommended standard way)

Moving cart on ground

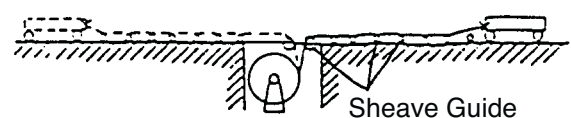

(not recommended due to the additional kinetic friction).

T20 Motor Cable Reel

Application: Cable Dim $14\text{mm}^2 \sim 38\text{mm}^2$ 、Horizontally Furl Length $50\text{M} \sim 100\text{M}$ 、Vertically Furl 30M . It Is Suitable For Kinds of Automatic Assemble Line

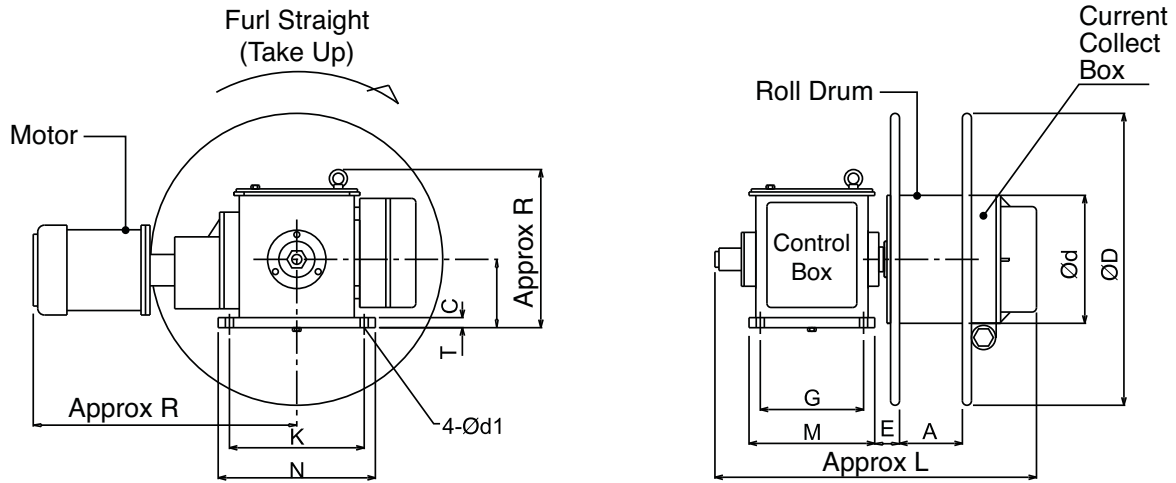

Chart 1

● Specification

Type	Maximum Poles	Chart	O.D					
			D	d	A	C	E	L
PWLM-T20H-0514	20	Chart 1	490	285	170	150	40	720
PWLM-T20H-0714	20	Chart 1	650	285	170	150	40	720
PWLM-T20H-0914	20	Chart 1	900	285	170	150	40	720
PWLM-T20H-1314~1338	4	Chart 2	1300	655	100	150	60	790
PWLM-T20H-1814~1838	4	Chart 2	1800	655	100	150	60	790

● Type Choice Reference (Horizontally Furl)

Cable Length Dimension	Suitable Type						
	50m	60m	70m	80m	90m	100m	110m
$14\text{mm}^2 \times 3\text{C}$	T20H-0514	T20H-0714					T20H-0914
$14\text{mm}^2 \times 4\text{C}$	T20H-0714				T20H-0914		
$22\text{mm}^2 \times 3\text{C}$	T20H-1322						T20H-1822
$22\text{mm}^2 \times 4\text{C}$	T20H-1322						—
$38\text{mm}^2 \times 3\text{C}$	T20H-1338				T20H-1838		—
$38\text{mm}^2 \times 4\text{C}$	T20H-1338				T20H-1838		—

● Type Choice Reference (Vertically Furl)

T20H-1308~1314 Adopted When Vertically Furl Cable Dim $8\text{mm}^2 \times 4\text{ pole} \sim 14\text{mm}^2 \times 4\text{ pole}$ length in 30M .

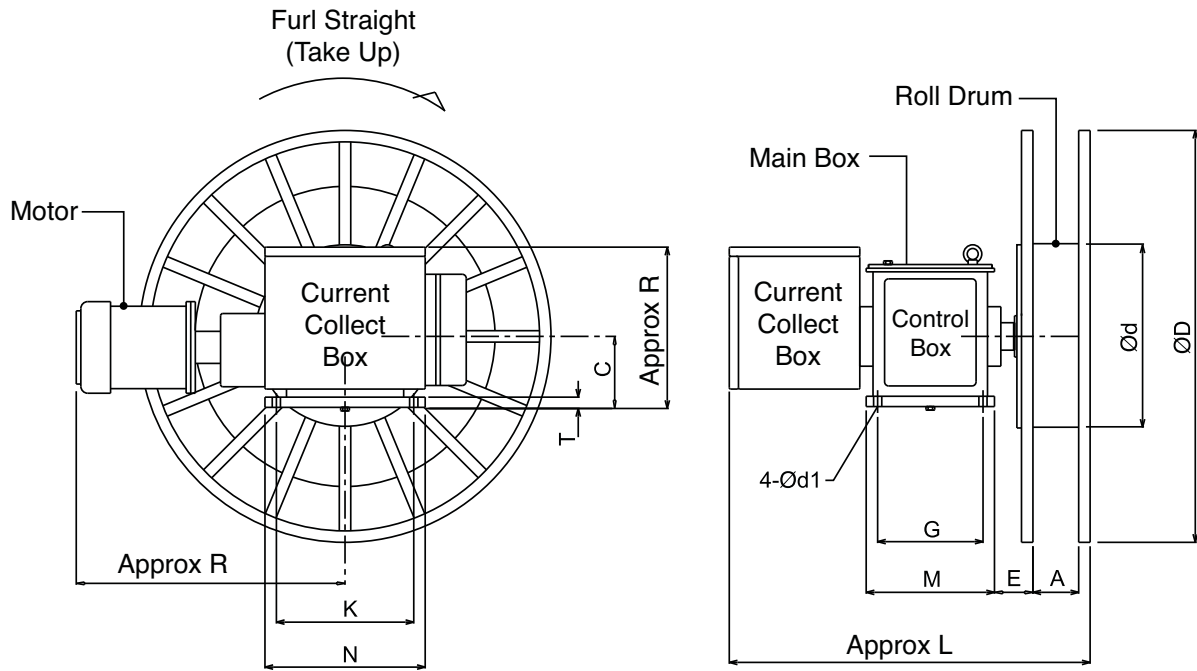
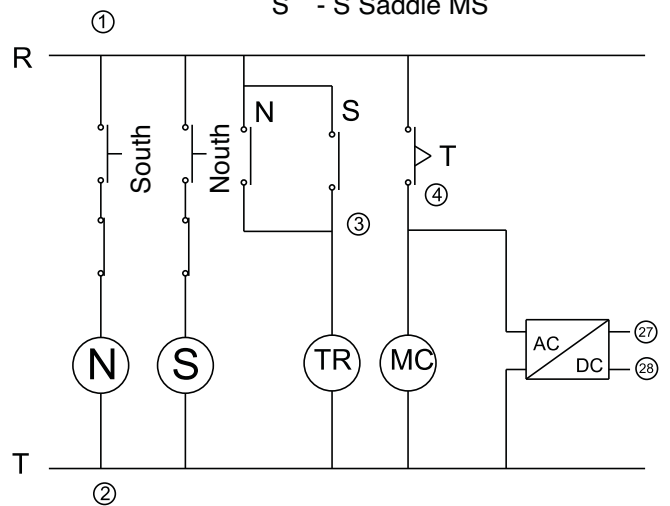
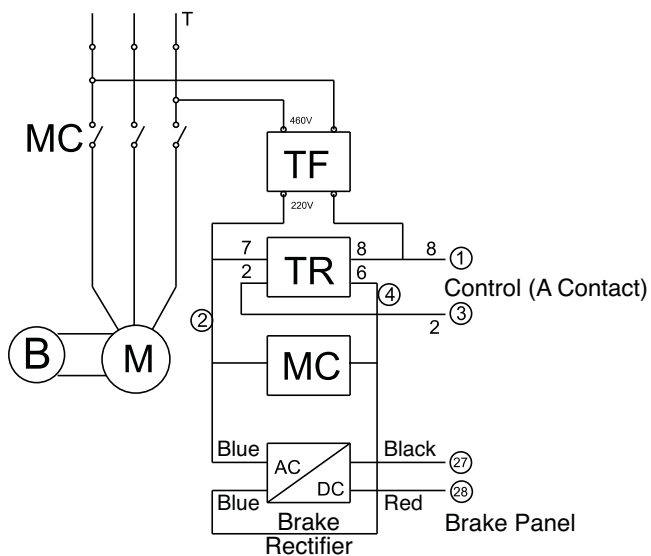

Chart 2

Specification									Remark
R	S	P	G ± 1	K ± 1	M	N	T	d1	
600	—	310	230	300	280	350	23	18	
600	—	310	230	300	280	350	23	18	
600	—	310	230	300	280	350	23	18	
600	—	345	230	300	280	350	23	18	
600	—	345	230	300	280	350	23	18	

● T20 T20.1 Control Panel Explanation

- TF - Transformer
- TR - Off Timer Switch
- MC - Magnetic Switch (MS)
- B - Brake Coil
- N - N Saddle MS
- S - S Saddle MS



T20.1 T40 Motor Cable Reel

Application: Cable Dim 22mm²~100mm²、Horizontally Furl Length 50M~160M、Vertically Furl 30M. It Is Suitable For Flexible Design And Special Format Made-On-Demand.

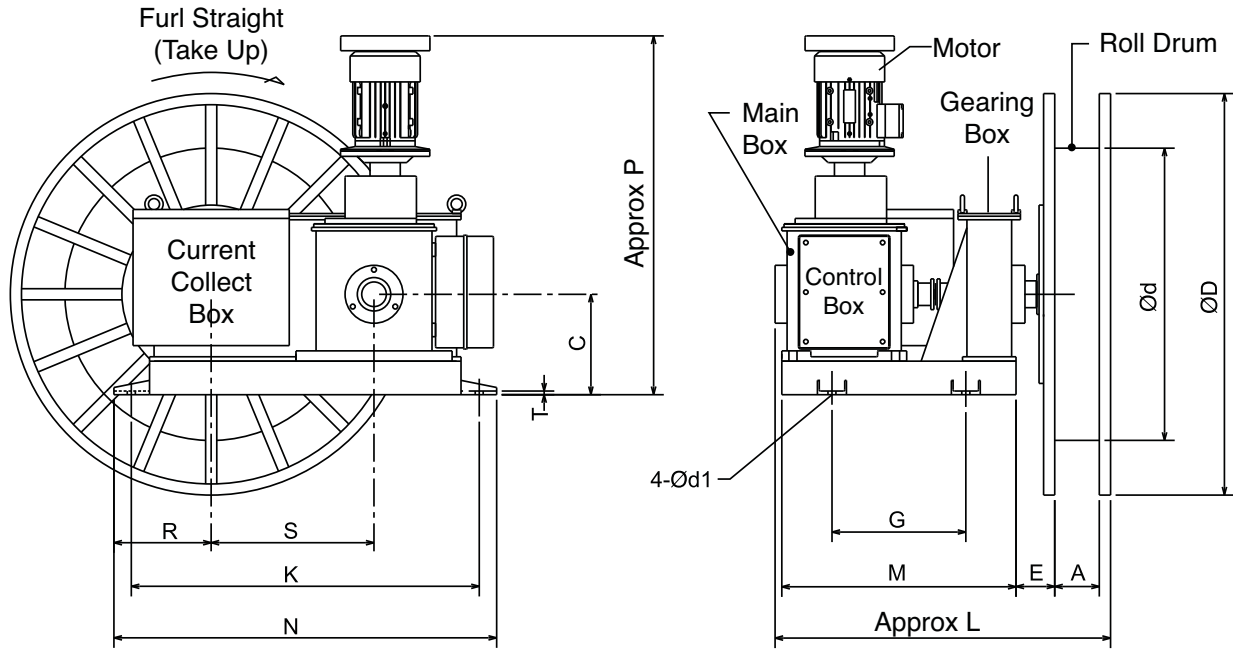

Chart 1

Specification

Type	Maximum Poles	Chart	O.D					
			D	d	A	C	E	L
PWLM-T20.1H-1522~1538	4	Chart 1	1500	655	100	225	87	755
PWLM-T20.1H-1822~1838	4	Chart 1	1800	655	100	225	87	755
PWLM-T40H-1822~1899	4	Chart 2	1800	850	100	208	100	820
PWLM-T40H-2022~2099	4	Chart 2	2000	850	100	208	100	820

Type Choice Reference (Horizontally Furl)

Cable Length Cable Dimension	Suitable Type					
	50m~70m	80m~90m	100m	110m	120m~140m	150m~160m
22mm ² × 3C	—	—	—	—	T20.1H-1822	T40M-1822
38mm ² × 3C	—	—	—	T40M-1838	T40M-2038	—
60mm ² × 3C	T20.1H-1560	T40M-1860	T40M-2060	T40M-2060	T40M-2060	—
100mm ² × 3C	T40-2099	—	—	—	—	—

Type Choice Reference (Vertically Furl)

T20.1H-1522~1538 Adopted When Vertically Furl Cable Dim 22mm²×4 pole~38 mm²×4 pole length in 30M.

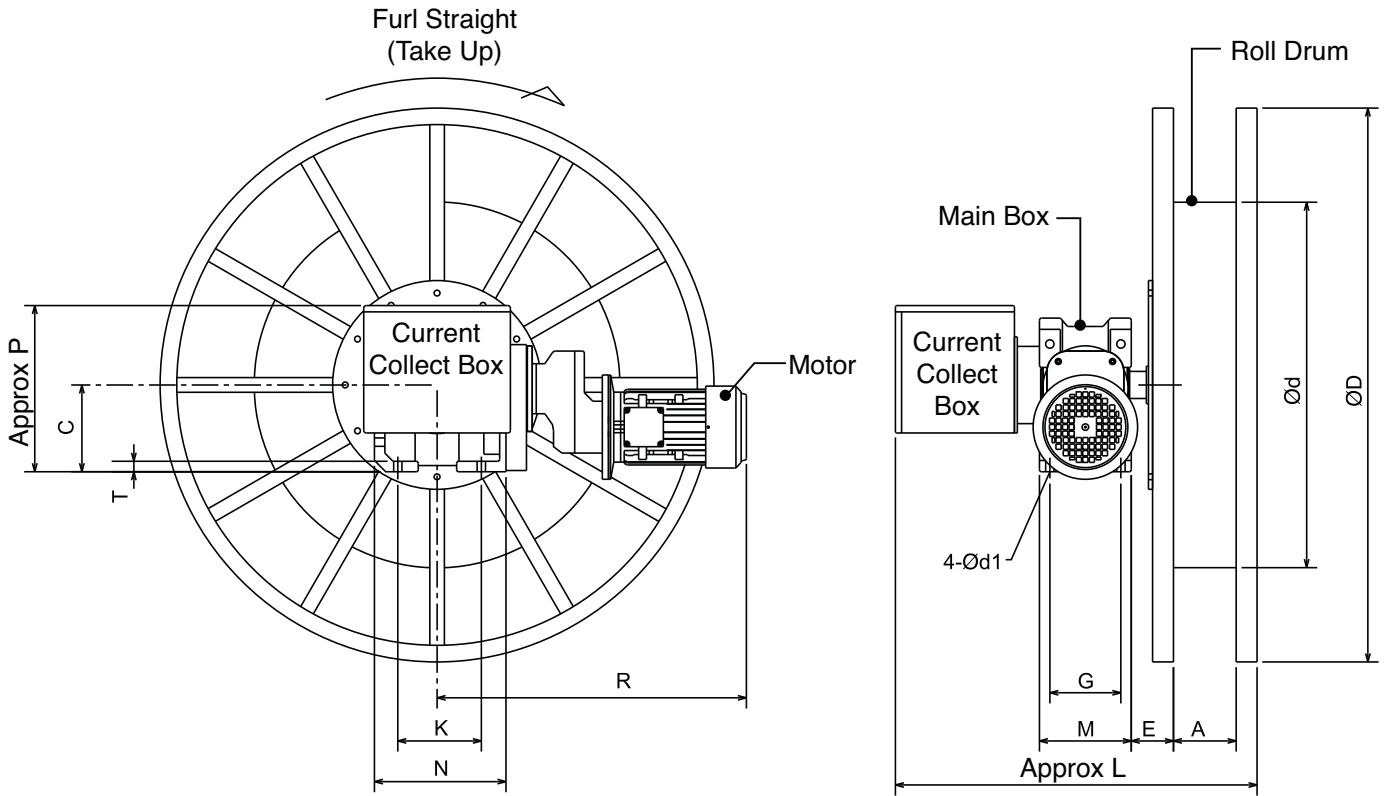
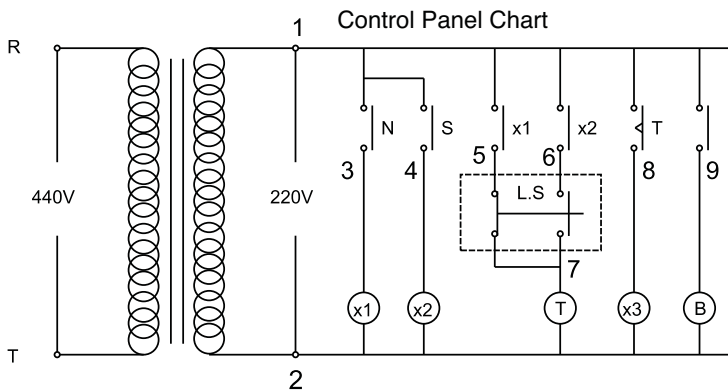

Chart 2

Specification									Remark
R	S	P	G ± 1	K ± 1	M	N	T	d1	
218	365	810	300	780	545	850	12	18	
218	365	810	300	780	545	850	12	18	
740	—	400	170	200	220	315	25	20	
740	—	400	170	200	220	315	25	20	

● T40 Control Panel Explanation



- N - N Saddle MS
- S - S Saddle MS
- x1 - Straight Relay
- x2 - Reverse Relay
- x3 - Variable Frequency Start Relay
- T - Timer Relay
- B - Brake MS
- L.S - Sheave Guide

M10、M15 Motor Cable Reel

Application: Cable Dim $5.5\text{mm}^2 \sim 14\text{mm}^2$, Horizontally Furl Length 50M~100M.
For Low Noise And Thin Cable With Many Poles.

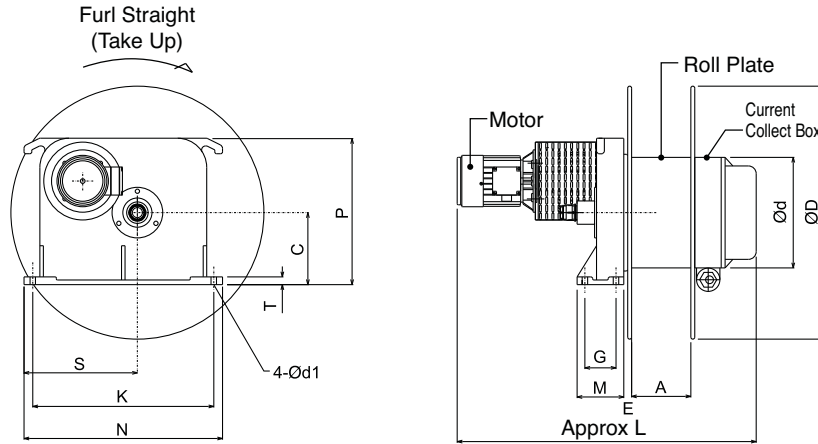

Chart 1

Specification

Type	Maximum Poles	Chart	O.D					
			D	d	A	C	E	* L
PWLS-M10S-0505~0814	15	Chart 1	490	285	170	185	10	770
PWLS-M10S-0705~0514	15	Chart 1	650	285	170	185	10	770
PWLS-M15S-0905~0914	20	Chart 2	900	285	170	150	40	720

※ Remark: PWLS-M15S-0914 Maximum Horizontally Furl Length is 100M

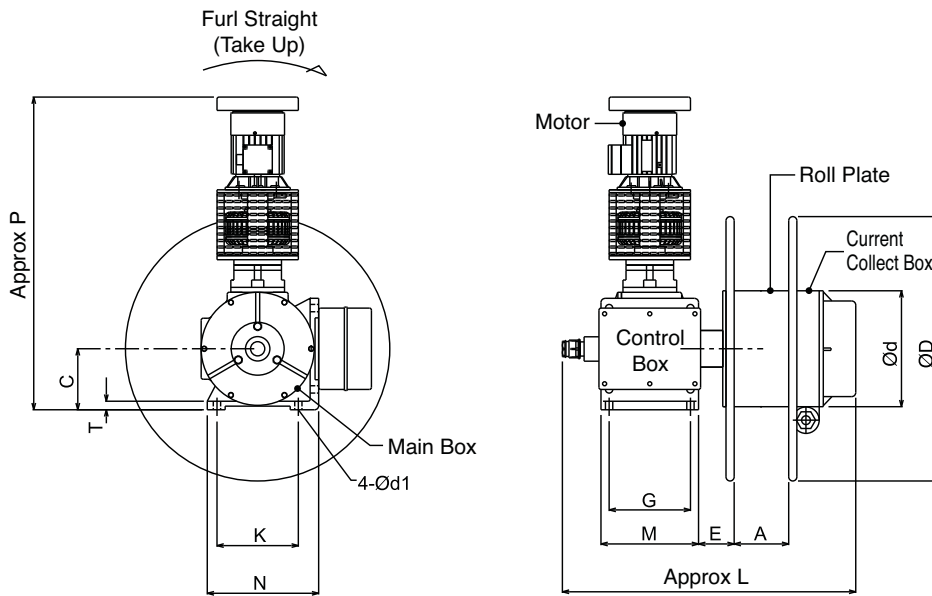
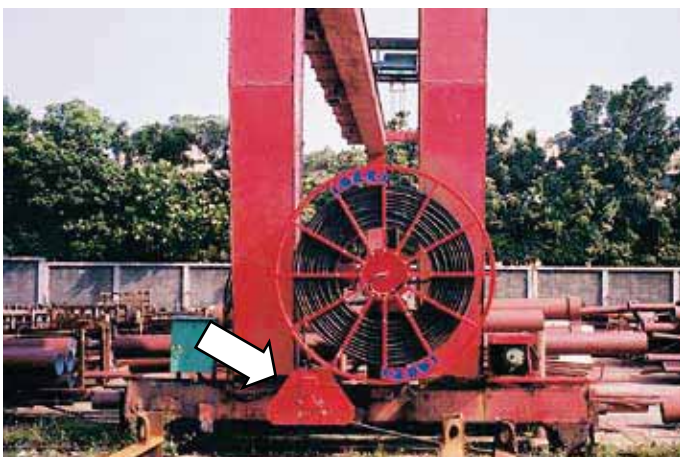
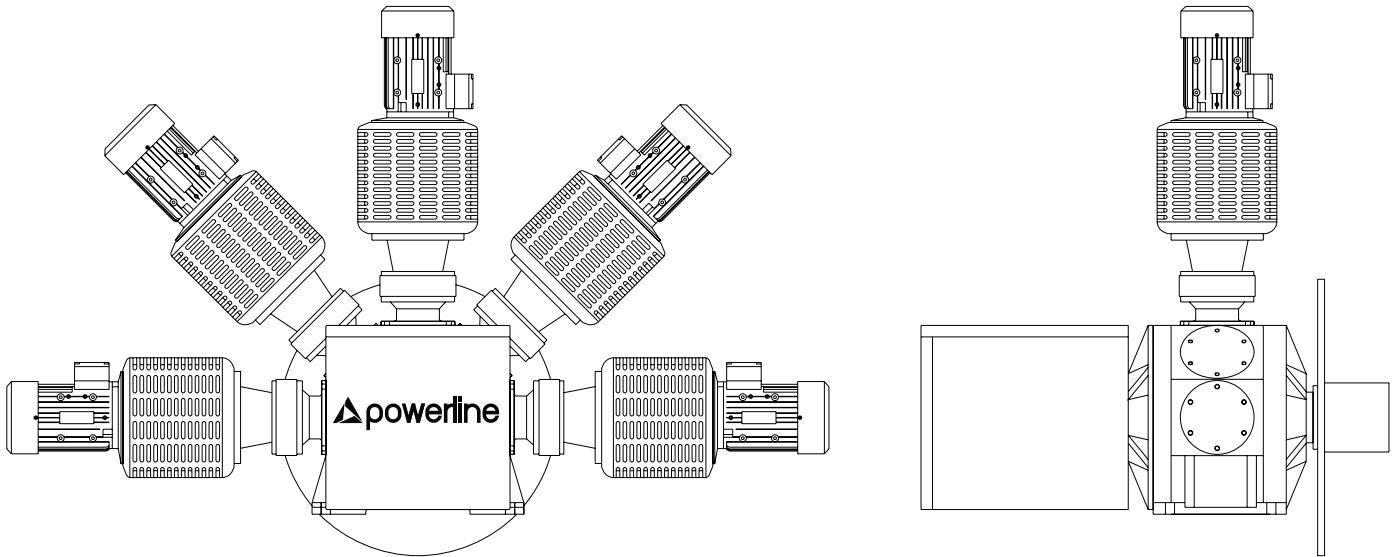

Chart 2

Specification									Remark
R	S	P	G ± 1	K ± 1	M	N	T	d1	
—	284	376	80	465	120	510	12	14	
—	284	376	80	465	120	510	12	14	
—	—	770	200	200	240	274	21	18	

M50 Motor Cable Reel

- Maximum Furl Length 200M With Cable Dim 60mm²
Maximum Furl Length 100M With Cable Dim 100mm²
- Applications: Heavy Duty And Thick Cable



CSBC Gantry Crane Motor Cable Reel



Moving Cart Motor Cable Reel

Definition of Our Type

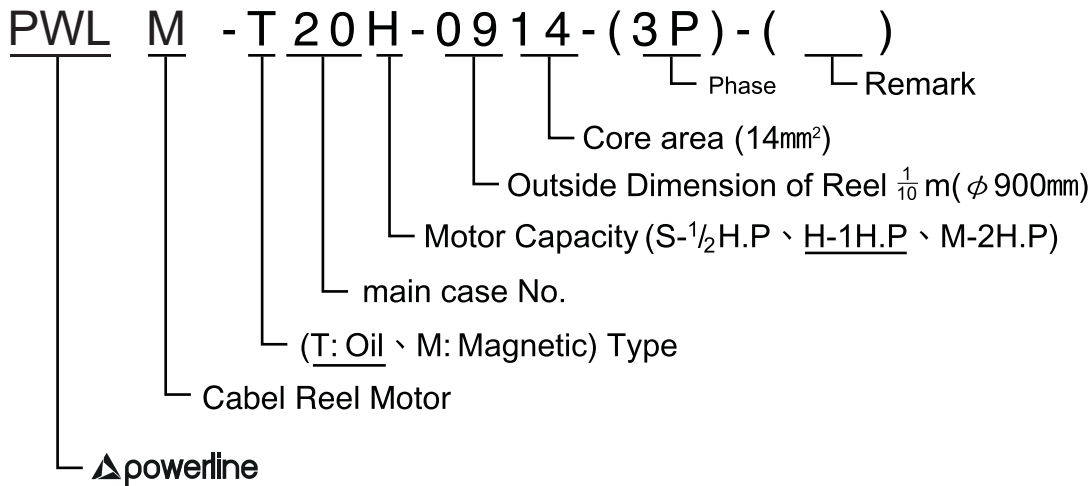

Questionnaire of Cable Reel

- What kind of the moving equipment is the cable reel for? _____
Please see the application example displayed on page 5 and pictures.
- Height of the reel installation _____ m
- Total travel distance of your equipment _____ m
- How long is the cable on the reel? _____ m
- Cable Payout From Center One End
- Type of application (see page 5)
- Specification of Cable?(no. of conductors \times wire size) _____ \times _____ mm²
Weight _____ kg/m
O.D _____ mm
- Capacity of Electrical Load _____ kw
Or amperes at _____ V _____ A
- What is the duty cycle of full load? _____ %
- How many poles of slip ring required? _____ pcs
- How many movements per hour? _____ times
- What's the operating hours per day? _____ hrs
- Maximum travel speed? _____ m/min
- 0 to full acceleration or accelerate rate _____ sec.
_____ m/sec

Other Data:
